

HALg3-4, 2.6 Notes – Rational Functions and Asymptotes

A **Rational Function** is a function in the form of a ratio of polynomials:

$$f(x) = \frac{N(x)}{D(x)} \quad \text{examples: } f(x) = \frac{3x^2 - 2}{4x^3 - x^2 + 2x - 1} \quad g(x) = \frac{1}{x}$$

domain of a rational function = all real numbers except where denominator is zero

Find domain of: $f(x) = \frac{1}{x} \quad \mathbb{R}, x \neq 0$ $f(x) = \frac{3x^2 - 5x + 2}{(x+3)(x-2)} \quad \mathbb{R}, x \neq -3, x \neq 2$

What do the graphs of these functions look like?

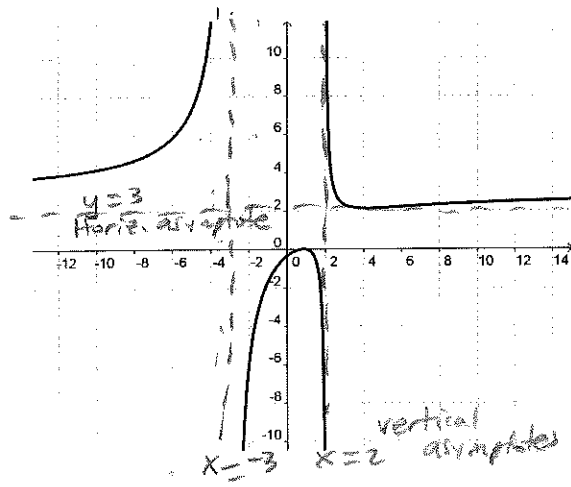
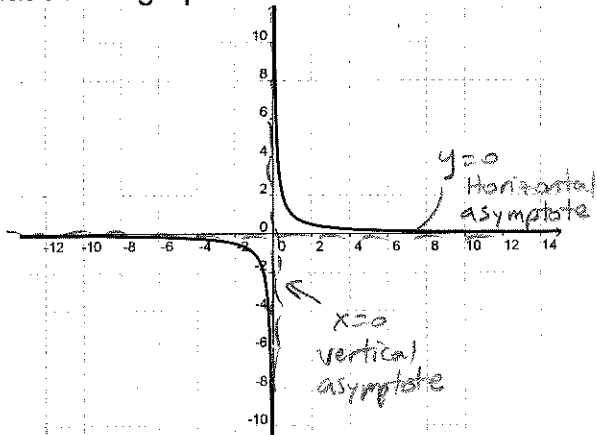

How to find the Asymptotes of a Rational Function: $f(x) = \frac{N(x)}{D(x)}$

Vertical asymptotes: graph of f has vertical asymptotes at the zeros of denominator $D(x)$

Horizontal asymptotes: graph of f has, at most, one horizontal asymptote, determined by the degrees of the numerator polynomial (n) and the denominator polynomial (m).

- If $n < m$, the line $y = 0$ (x -axis) is a horizontal asymptote.
- If $n = m$, the line $y = \frac{a_n}{b_m}$ is a horizontal asymptote.
- If $n > m$, the graph has no horizontal asymptote but may have a slant asymptote.

$f(x) = \frac{2x}{3x^2 + 1} \quad n=1, m=2 \quad \text{Horiz. asymptote } y=0$

 $f(x) = \frac{5x}{(x-1)} \quad n=1, m=1 \quad \text{H.A. } y=5$

 $f(x) = \frac{2x^3}{3x^2 + 1} \quad n=3, m=2 \quad \text{No H.A.}$

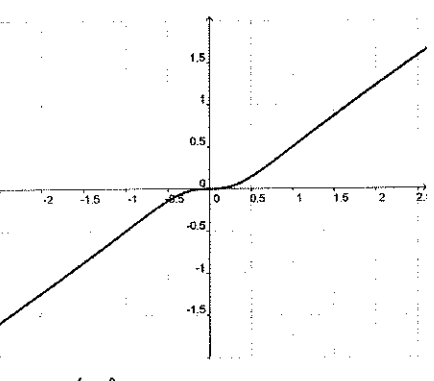
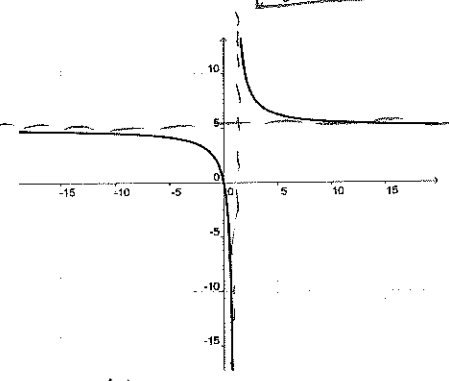
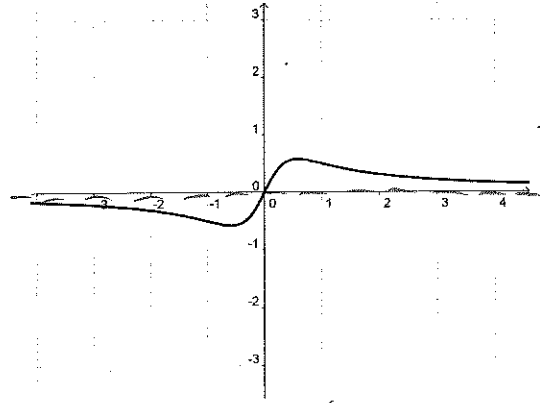

Vertical asymptote: (denom=0)
 $3x^2 + 1 = 0 \quad 3x^2 = -1$
 $x^2 = -1/3 \quad x = \pm \sqrt{-1/3}$
no vert. asymptote

V.A.:
 $x - 1 = 0$
 $x = 1$

V.A.:
 $3x^2 + 1 = 0$
 $x = \pm \sqrt{-1/3}$
No V.A.

(another, more conceptual, way to find horizontal asymptotes)

Think about what happens when x is very large. The non- x terms become negligible and can be removed. Then simplify the result:

$$f(x) = \frac{2x}{3x^2 + 1}$$

for large x \uparrow 1 is negligible

$$f(x) \approx \frac{2x}{3x^2}$$

$$= \frac{x(2)}{x(3x)}$$

$$= \frac{2}{3x}$$

as $x \rightarrow \infty$
 $f(x) \rightarrow 0$
 so H.A. is $y = 0$

$$f(x) = \frac{5x}{x-1}$$

for large x \leftarrow negligible

$$f(x) \approx \frac{5x}{x}$$

$$= 5$$

so H.A. is $y = 5$

$$f(x) = \frac{2x^3}{3x^2 + 1}$$

for large x \leftarrow negligible

$$f(x) \approx \frac{2x^3}{3x^2}$$

$$= \frac{x(2x^2)}{x^2(3)}$$

$$= \frac{2x}{3}$$

as $x \rightarrow \infty$
 $f(x) \rightarrow \infty$
 never settled to a number, so
 No H.A.

Applications – many real-world problems exhibit ‘asymptotic behavior’ (approach a value)

A business has a cost function $C = 0.5x + 5000$ where C is cost in dollars and x is number of units produced.

- What is the average cost per unit when the number of units is 1000, and 10,000.
- What is the average cost per unit when a very large number of units is produced?

Avg. cost per unit $A(x) = \frac{C(x)}{x} = \frac{0.5x + 5000}{x}$

Vertical asymptote: when $x = 0$

horizontal asymptote: $n=1, m=1 \quad n=m \quad \frac{0.5x + 5000}{x}$

so H.A. $y = 0.5$

$$A(1000) = 5$$

$$A(10000) = 1$$

$$\lim_{x \rightarrow \infty} A(x) = 0.5$$

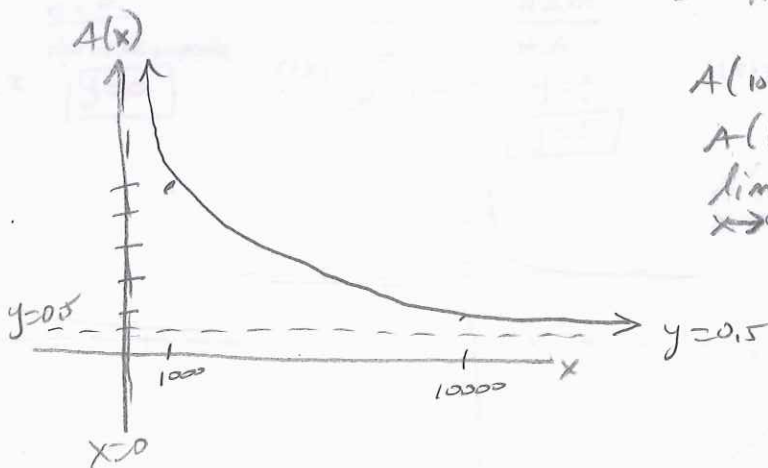

HA1g3-4, 2.7 Notes – Graphs of Rational Functions

Finding slant asymptotes:

Example: Find horizontal asymptote of $f(x) = \frac{x^2 - x}{x + 1}$ $k = 2$
 $m = 1$.

$n > m$, no horizontal asymptote — or — for large x : $\approx \frac{x^2 - x}{x}$
 $\approx x - 1$
 $\approx \infty$

Slant asymptotes exist when degree of numerator is exactly one greater than degree of denominator. **Find equation of line of slant asymptote by dividing the polynomials.** The quotient (without remainder) is the equation of the slant asymptote.

$$\begin{array}{r} x - 2 \\ x + 1 \overline{) x^2 - x + 0} \\ \underline{x^2 + x} \\ -2x + 0 \\ \underline{-2x - 2} \\ 2 \end{array}$$

or
by
synthetic
division:

$$\begin{array}{r|rrr} -1 & 1 & -1 & 0 \\ & & -1 & 2 \\ \hline & 1 & -2 & 2 \end{array}$$

$x - 2 \quad R 2$

$y = x - 2$

$x - 2 + \frac{2}{x + 1}$

↖ this becomes negligible

slant asymptote:
 $y = x - 2$

Vertical asymptote where denominator = 0: $x = -1$

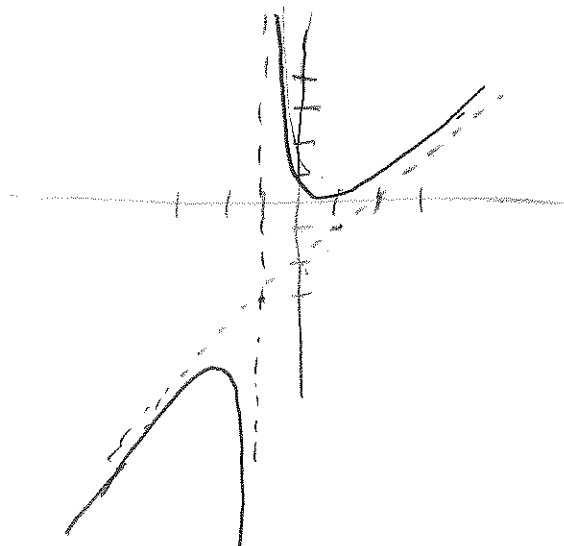

Sketching rational functions

- 1) Find $f(0)$ (plug in 0 for x)...this gives y -intercept (if any).
- 2) Find zeros of numerator polynomial...this gives x -intercepts (if any).
- 3) Find zeros of denominator polynomial...this gives vertical asymptotes (if any).
- 4) Use entire rational function to find horizontal or ^{slant}slope asymptotes (if any).
- 5) Plot above on graph and find at least one point in each 'region'.
- 6) Finish sketch with smooth curve.

Example: sketch $f(x) = \frac{x}{x^2 - x - 2}$

1) $f(0) = \frac{0}{0^2 - 0 - 2} = \frac{0}{-2} = 0$ y -int: $(0, 0)$

2) $x = 0$ x -int: $(0, 0)$

3) $x^2 - x - 2 = 0$
 $(x-2)(x+1) = 0$

Vertical asymptotes at: $x = 2, x = -1$

$$\frac{x}{x^2 - x} = \frac{1}{x-1}$$

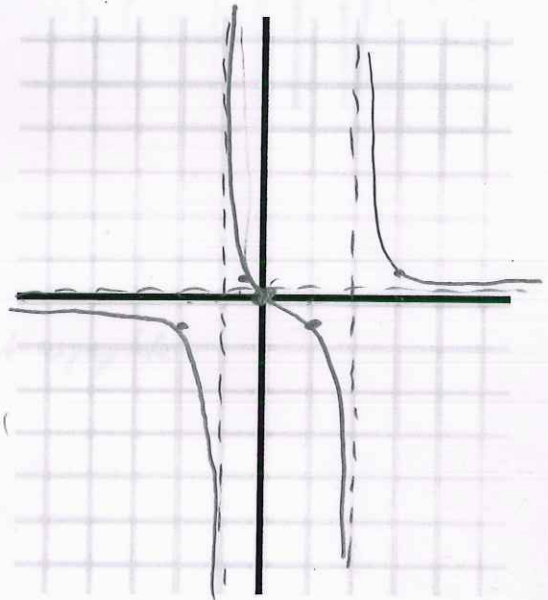

4) $n = 1$
 $m = 2$
 $n < m$, horiz. asymptote $y = 0$

5)

x	$f(x)$
-2	$\frac{-2}{4+2-2} = \frac{-2}{4} = -\frac{1}{2}$ $(-2, -\frac{1}{2})$
$-\frac{1}{2}$	$\frac{-\frac{1}{2}}{\frac{1}{4} + \frac{1}{2} - 2} = \frac{-\frac{1}{2}}{\frac{1}{4} + \frac{2}{4} - \frac{8}{4}} = \frac{-\frac{1}{2}}{-\frac{5}{4}} = -\frac{1}{2} \cdot (-\frac{4}{5}) = \frac{2}{5}$ $(-\frac{1}{2}, \frac{2}{5})$
1	$\frac{1}{1-1-2} = \frac{1}{-2} = -\frac{1}{2}$ $(1, -\frac{1}{2})$
3	$\frac{3}{9-3-2} = \frac{3}{4}$ $(3, \frac{3}{4})$

Example: sketch $f(x) = \frac{x^2 - x - 2}{x - 1}$

1) $f(0) = \frac{0^2 - 0 - 2}{0 - 1} = \frac{-2}{-1} = 2$ y-int $(0, 2)$

2) $x^2 - x - 2 = 0$ x-int: $(2, 0)$ and $(-1, 0)$
 $(x - 2)(x + 1) = 0$

3) $x - 1 = 0$
 $x = 1$ vertical asymptote

4) horiz. asymptote: for larger x $\frac{x^2 - x}{x}$
 $\approx x - 1$
 $\neq 0$ no horiz.

but is one greater than x , so slant asymptote:

$$\begin{array}{r} x \\ x-1 \overline{) x^2 - x - 2} \\ \underline{x^2 - x} \\ -2 \end{array}$$

$$x - \frac{2}{x-1}$$

$y = x$ slant asymptote

5)

x	f(x)
-2	$\frac{4 + 2 - 2}{-2 - 1} = \frac{4}{-3} = -\frac{4}{3}$ $(-2, -\frac{4}{3})$
4	$\frac{16 - 4 - 2}{4 - 1} = \frac{10}{3}$ $(4, \frac{10}{3})$
$\frac{3}{2}$	$\frac{\frac{9}{4} - \frac{3}{2} - 2}{\frac{3}{2} - 1} = \frac{\frac{9}{4} - \frac{6}{4} - \frac{8}{4}}{\frac{3}{2} - \frac{2}{2}} = \frac{-\frac{5}{4}}{\frac{1}{2}} = (-\frac{5}{4})(2) = -\frac{5}{2}$ $(\frac{3}{2}, -\frac{5}{2})$

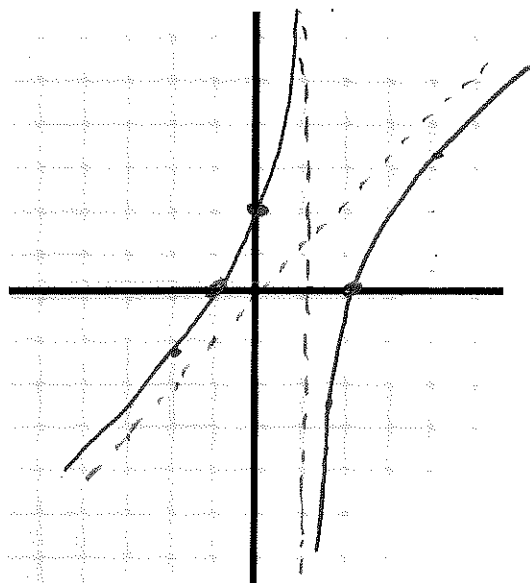

Precalculus /

HA1g3-4, 10.1 Notes – Conic Sections and Parabolas

Conic Sections – curves formed by intersection of a double-napped cone with a plane.

The shape of the intersection curve depends upon the angle the plane makes with the vertical axis of the cone:

Circle - if the plane is perpendicular to the cone axis, the curve is a circle.

Ellipse – if the plane's angle is greater than the vertex angle, but not perpendicular to cone axis, the curve is an ellipse.

Parabola – if the plane's angle matches the vertex angle, the curve is a parabola.

Hyperbola – if the plane's angle is smaller than the vertex angle, the curve cuts through both nappes and is a hyperbola.

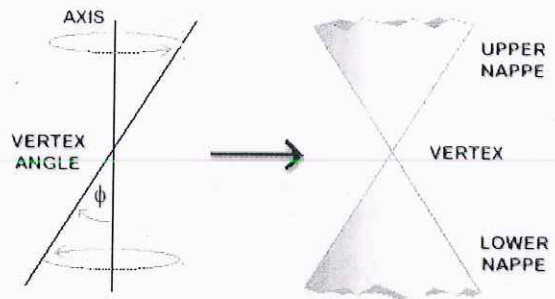

CIRCLE

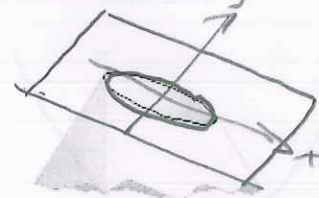

ELLIPSE



PARABOLA



HYPERBOLA

Conic Sections are defined by the general equation: $Ax^2 + Bxy + Cy^2 + Dx + Ey + F = 0$
 ...but each curve has a standard form that makes it easier to sketch.

Parabola = The set of all points (x,y) that are equidistant from a fixed line (called the directrix) and a fixed point (called the focus).

Applications – reflectors (flashlight, antenna dishes)

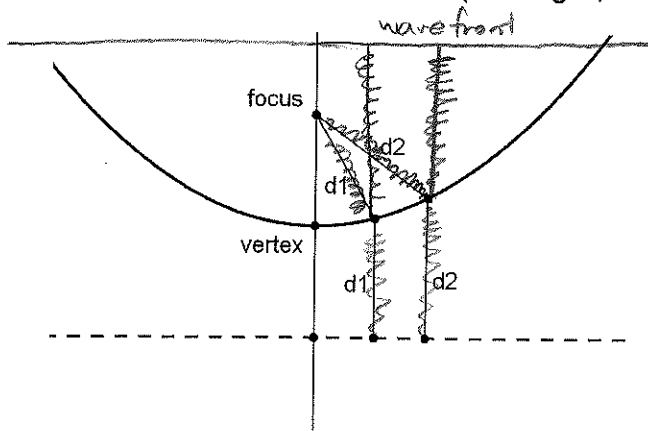

Let's look at an example: $y = \frac{1}{4}x^2 - x + 2$

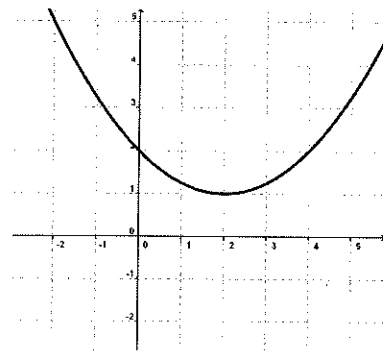

How could we graph this by hand? Easier to graph if we change the equation into the standard form equation for a parabola:

$$y = \frac{1}{4}x^2 - x + 2$$

$$\frac{1}{4}x^2 - x = y - 2 \quad (\text{x terms on left, everything else on rt.})$$

$$x^2 - 4x = 4y - 8 \quad (\text{make } x^2 \text{ coefficient 1})$$

$$x^2 - 4x + 4 = 4y - 8 + 4 \quad (\text{complete the square})$$

$$(x-2)^2 = 4y - 4$$

$$(x-2)^2 = 4(y-1) \quad (\text{factor right side})$$

vertex: $(2, 1)$

To find another point find an intercept

$$y \text{ int } (x=0) \quad (0-2)^2 = 4(y-1)$$

$$(-2)^2 = 4(y-1)$$

$$4 = 4(y-1)$$

$$1 = y-1 \quad y=2 \quad (0, 2)$$

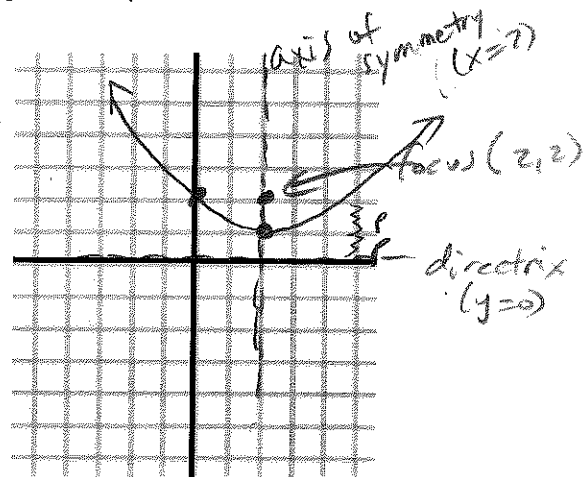

$$(x-2)^2 = 4(y-1)$$

↑
this number is $4p$

Standard form equation of a parabola:

Vertical axis:

$$(x-h)^2 = 4p(y-k)$$

Vertex: (h, k)

Focus: $(h, k+p)$

Directrix: $y = k - p$

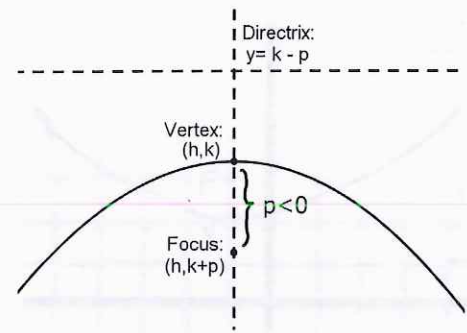
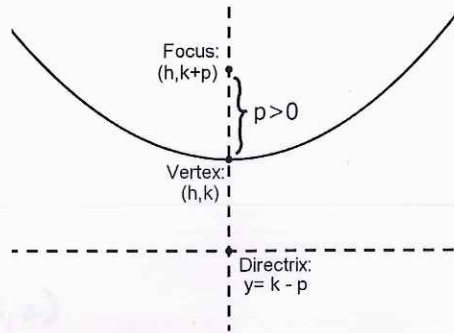

Horizontal axis:

$$(y-k)^2 = 4p(x-h)$$

Vertex: (h, k)

Focus: $(h+p, k)$

Directrix: $x = h - p$

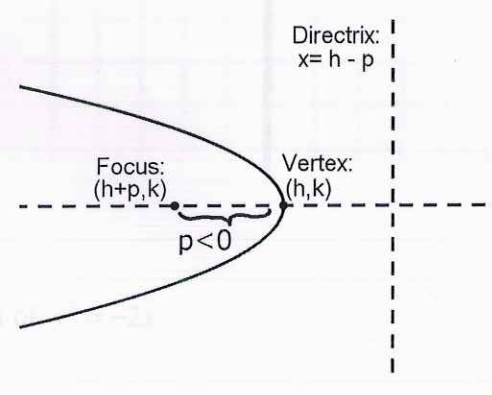
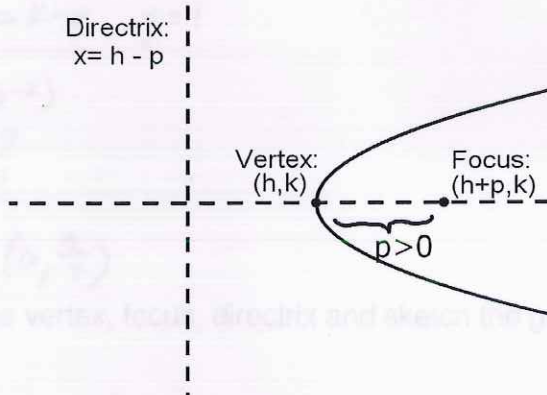

For all parabolas: $p =$ distance between focus and vertex *(and vertex to directrix)*

**To sketch, plug in $x=0$ or $y=0$ to find an intercept.
(Curve is symmetric about its axis)**

(parabolas don't have asymptotes)

Handwritten notes:
 $y = -2, p = -\frac{1}{2}$
 vertex $(h, k) = (1, 2)$
 focus $(h+p, k) = (\frac{1}{2}, 2)$
 directrix $x = h-p, x = \frac{3}{2}$
 $p = -\frac{1}{2}, x = 1$
 $y^2 = -2(x-1)$
 $y^2 = 0$
 $y = \pm\sqrt{2} \pm 1$

Example: Find the vertex, focus, directrix and sketch the graph of $(x+1)^2 = 4(y-2)$

$$(x+1)^2 = 4(y-2)$$

$$(x-h)^2 = 4p(y-k)$$

$$h = -1$$

$$k = 2$$

$$4p = 4, p = 1$$

$$\text{vertex: } (h, k) = (-1, 2)$$

$$\text{focus: } (h, k+p) = (-1, 3)$$

$$\text{directrix: } y = k-p, y = 1$$

$$(0+1)^2 = 4(y-2)$$

$$1 = 4y - 8$$

$$\begin{array}{r} +8 \\ \hline 9 = 4y \end{array}$$

$$\frac{9}{4} = y \quad \left(0, \frac{9}{4}\right)$$

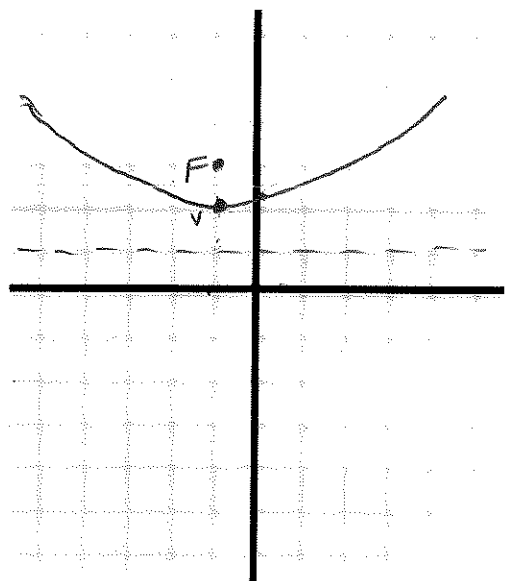

Example: Find the vertex, focus, directrix and sketch the graph of $y^2 = -2x$

$$y^2 = -2x$$

$$(y-k)^2 = 4p(x-h)$$

$$(y-k)^2 = 4p(x-h)$$

$$h = 0$$

$$k = 0$$

$$4p = -2, p = -\frac{1}{2}$$

$$\text{vertex } (h, k) = (0, 0)$$

$$\text{focus } (h+p, k) = \left(-\frac{1}{2}, 0\right)$$

$$\text{directrix: } x = h-p, x = \frac{1}{2}$$

$$\text{plug in } x = -1$$

$$y^2 = -2(-1)$$

$$y^2 = 2$$

$$y = \pm\sqrt{2} \approx \pm 1.414$$

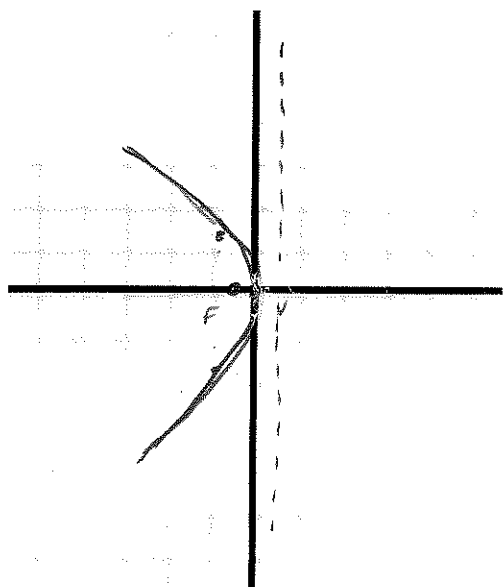

Example: Find the vertex, focus, directrix and sketch the graph of $x^2 - 2x + 8y + 9 = 0$

$$x^2 - 2x = -8y - 9$$

complete the square:

$$(x^2 - 2x + 1) - 1 = -8y - 9$$

$$(x-1)^2 - 1 = -8y - 9$$

$$(x-1)^2 = -8y - 8$$

$$(x-1)^2 = -8(y+1)$$

$$h=1$$

$$k=-1$$

$$4p = -8, p = -2$$

vertex: (h, k) $(1, -1)$

focus: $(h, k+p)$ $(1, -3)$

directrix: $y = k - p, y = 1$

$$(-1)^2 = -8y - 8$$

$$1 = -8y - 8$$

$$9 = -8y \quad y = -\frac{9}{8} \quad (0, -\frac{9}{8})$$

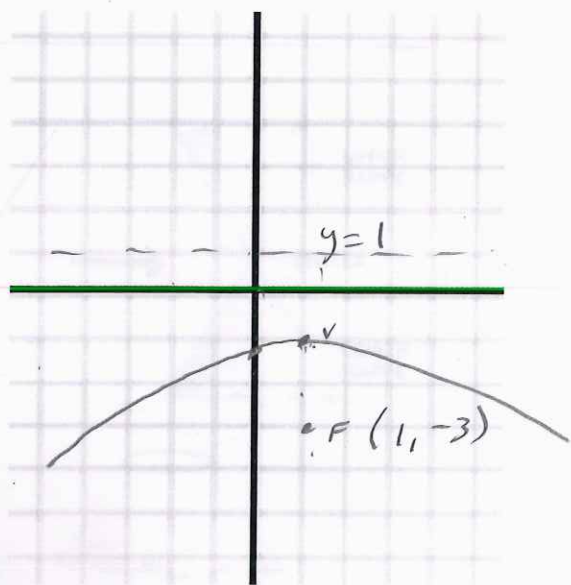

Example: Find standard form equation of a parabola with vertex at $(-1, 2)$ and focus at $(-1, 0)$

$$(x-h)^2 = 4p(y-k)$$

$$(x+1)^2 = 4p(y-2)$$

$$(x+1)^2 = 4(-2)(y-2)$$

$$\boxed{(x+1)^2 = -8(y-2)}$$

$$k=2$$

$$k+p=0$$

$$2+p=0$$

$$p=-2$$

h, k

$h, k+p$

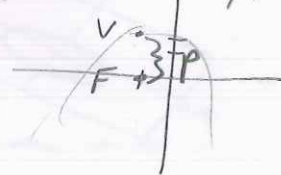

points down, $p < 0$

Example: Find standard form equation of a parabola with vertex at $(-2, 1)$ with directrix $x=1$

$$(y-k)^2 = 4p(x-h)$$

$$(y-1)^2 = 4p(x+2)$$

$$(y-1)^2 = 4(-3)(x+2)$$

$$\boxed{(y-1)^2 = -12(x+2)}$$

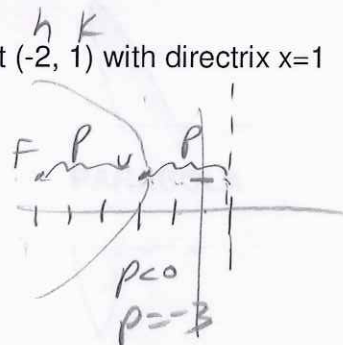

points left, $p < 0$

HAlg3-4, 10.2 Notes – Ellipses

Ellipse = the set of all points (x,y) the sum of whose distances from two fixed points (called foci) is constant.

real-life:

- orbits of planets, comets
- circles in perspective
- tanker truck cross section (lower center of gravity)

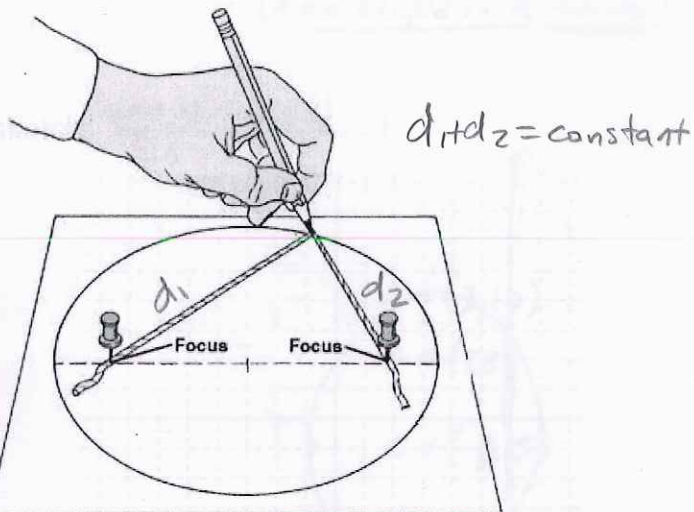

Standard form equation of an ellipse

Horizontal major axis

(bigger number under x^2 term)

$$\frac{(x-h)^2}{a^2} + \frac{(y-k)^2}{b^2} = 1$$

ex: $\frac{(x-1)^2}{9} + \frac{(y-2)^2}{4} = 1$

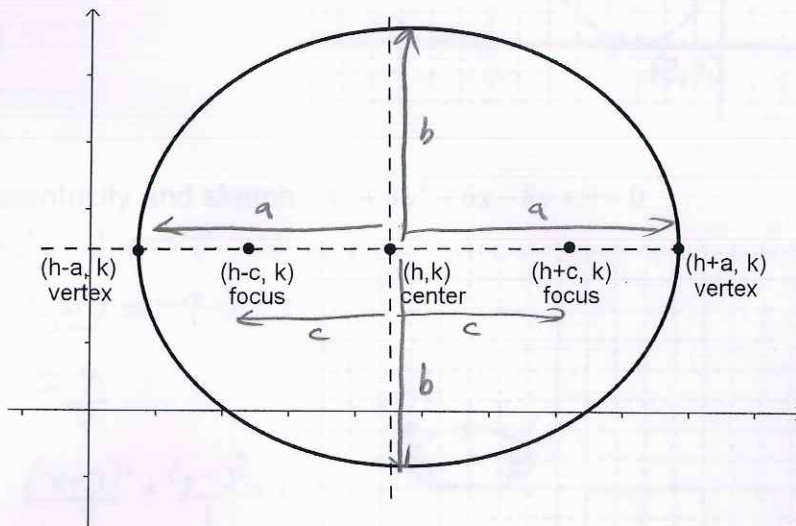

Vertical major axis

(bigger number under y^2 term)

$$\frac{(x-h)^2}{b^2} + \frac{(y-k)^2}{a^2} = 1$$

ex: $\frac{(x-1)^2}{4} + \frac{(y-2)^2}{9} = 1$

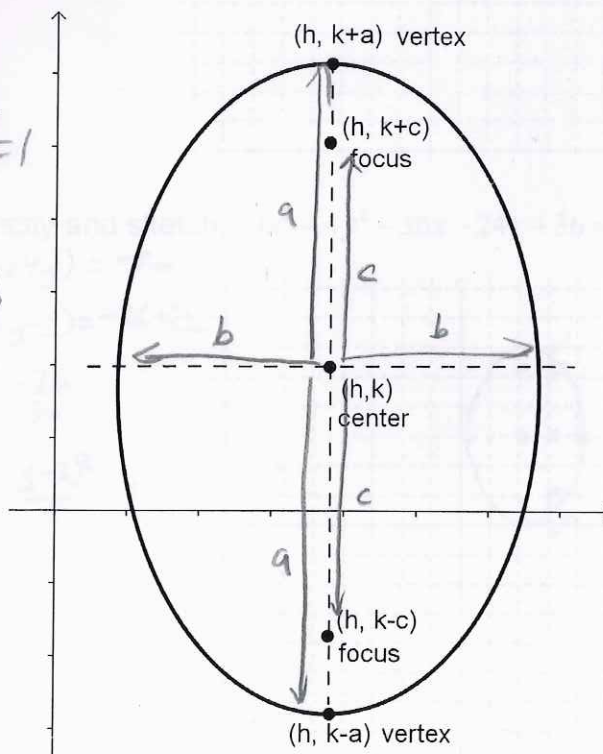

For all ellipses: a is always bigger than b

(h, k) = center

a = distance from center to a vertex on major (longer) axis

b = distance from center to a point on minor (shorter) axis

c = distance from center to a focus

$$c^2 = a^2 - b^2$$

Since $c^2 = a^2 - b^2$

Eccentricity: $e = \frac{c}{a}$ 'oval-ness' $0 < e < 1$

$e = 0$ when $c = 0$ when $a = b$
 ($a = b$ ellipse is a circle)

Examples...

#1 Find the center, vertices, foci and eccentricity and sketch: $\frac{(x+3)^2}{16} + \frac{(y-5)^2}{25} = 1$

bigger # under y, vertical major axis 

$a = \sqrt{25} = 5$

$b = \sqrt{16} = 4$

$c^2 = a^2 - b^2 = 25 - 16 = 9$

$c = 3$

Center: $(h, k) : (-3, 5)$

Vertices: $(h, k \pm a) : (-3, 10), (-3, 0)$

Foci: $(h, k \pm c) : (-3, 8), (-3, 2)$

Eccentricity: $e = \frac{c}{a} = \frac{3}{5}$

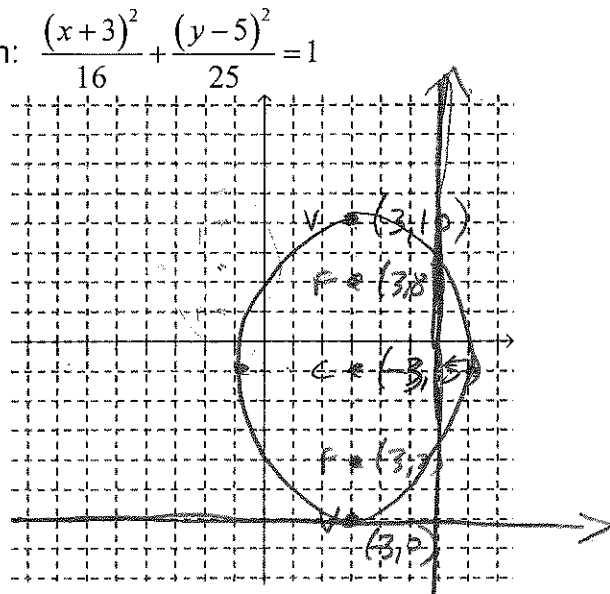

#2 Find the center, vertices, foci and eccentricity and sketch: $x^2 + 4y^2 + 6x - 8y + 9 = 0$

horiz. major axis $(x^2 + 6x) + (4y^2 - 8y) = -9$

$a = \sqrt{4} = 2$ $(x^2 + 6x + 9) + 4(y^2 - 2y + 1) = -9 + 9 + 4$

$b = 1$

$c^2 = 4 - 1 = 3$ $c = \sqrt{3}$ $\frac{(x+3)^2}{4} + \frac{(y-1)^2}{1} = \frac{4}{4}$

Center: $(h, k) : (-3, 1)$

Vertices: $(h \pm a, k) : (-1, 1), (-5, 1)$

Foci: $(h \pm c, k) : (-3 + \sqrt{3}, 1), (-3 - \sqrt{3}, 1)$

Eccentricity: $e = \frac{c}{a} = \frac{\sqrt{3}}{2}$

$\frac{(x+3)^2}{4} + \frac{(y-1)^2}{1} = 1$

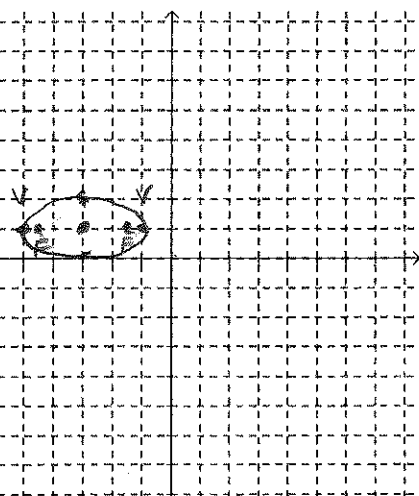

Try it... Find the center, vertices, foci and eccentricity and sketch: $9x^2 + 4y^2 - 36x - 24y + 36 = 0$

vertical major axis $(9x^2 - 36x) + (4y^2 - 24y) = -36$

$a = 3$

$b = 2$

$c^2 = 9 - 4 = 5$ $c = \sqrt{5}$

Center: $(2, 3)$

Vertices: $(2, 6), (2, 0)$

Foci: $(2, 3 + \sqrt{5}), (2, 3 - \sqrt{5})$

Eccentricity: $e = \frac{c}{a} = \frac{\sqrt{5}}{3}$

$9(x^2 - 4x + 4) + 4(y^2 - 6y + 9) = -36 + 36 + 36$

$\frac{9(x-2)^2}{36} + \frac{4(y-3)^2}{36} = \frac{36}{36}$

$\frac{(x-2)^2}{4} + \frac{(y-3)^2}{9} = 1$

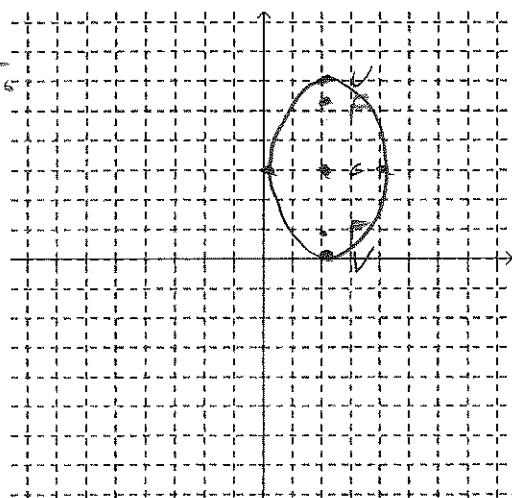

#3 Find the standard form of the equation of the ellipse if:

Vertices: (0,8) and (0,-8)

Foci: (0,4) and (0,-4)

$$\frac{(x-0)^2}{48} + \frac{(y-0)^2}{64} = 1$$

$$\frac{x^2}{48} + \frac{y^2}{64} = 1$$

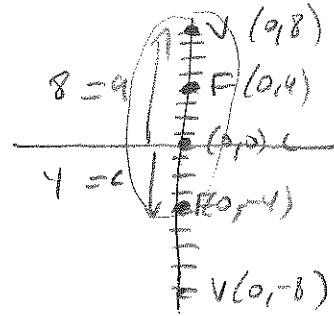

$$c^2 = a^2 - b^2$$

$$16 = 64 - b^2$$

$$b^2 = 64 - 16 = 48$$

#4 Find the standard form of the equation of the ellipse if:

Foci: (0,0) and (4,0)

Major axis of length 8

$$\frac{(x-2)^2}{16} + \frac{(y-0)^2}{12} = 1$$

$$\frac{(x-2)^2}{16} + \frac{y^2}{12} = 1$$

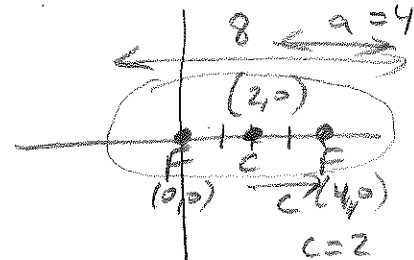

$$c = 2$$

$$c^2 = a^2 - b^2$$

$$4 = 16 - b^2$$

$$b^2 = 16 - 4$$

$$b^2 = 12$$

$$a^2 = 16$$

Try it... Find the standard form of the equation of the ellipse if:

Vertices: (3, 1) and (3, 9)

Minor axis of length 6

$$\frac{(x-3)^2}{9} + \frac{(y-5)^2}{16} = 1$$

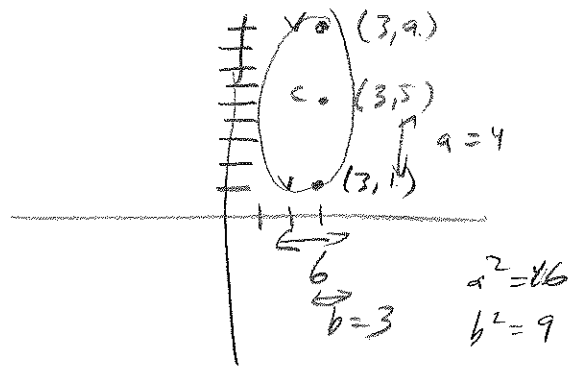

$$a^2 = 16$$

$$b^2 = 9$$

HAlg3-4, 10.3 Notes – Hyperbola

Hyperbola = the set of all points (x,y) the difference of whose distances from two fixed points (called foci) is a positive constant.

Standard form equation of a hyperbola (similar to ellipse, but – instead of + between terms)

Horizontal transverse axis (x^2 term is first)

$$\frac{(x-h)^2}{a^2} - \frac{(y-k)^2}{b^2} = 1$$

asymptotes at:

$$(y-k) = \pm \frac{b}{a}(x-h)$$

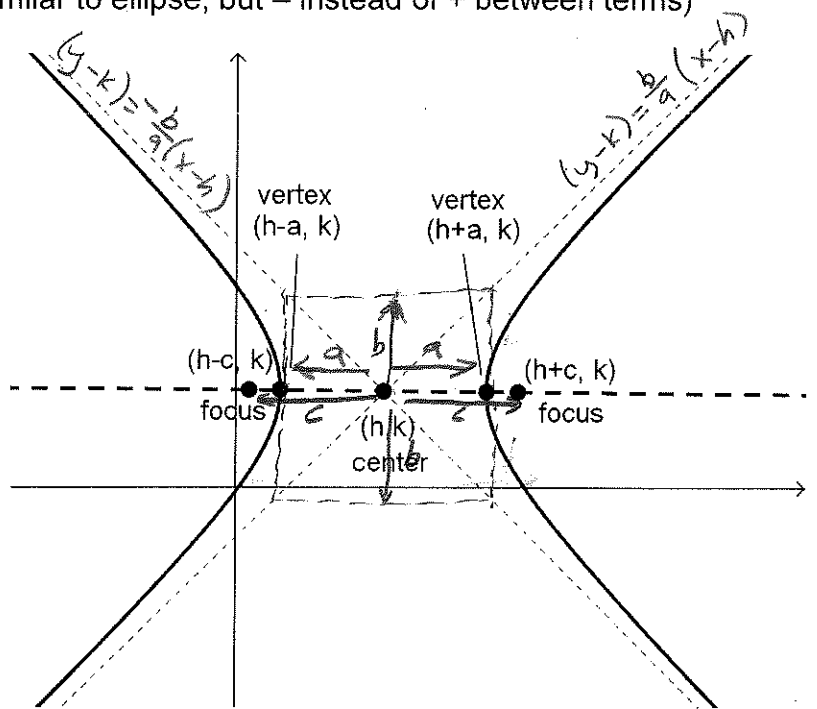

Vertical transverse axis (y^2 term is first)

$$\frac{(y-k)^2}{a^2} - \frac{(x-h)^2}{b^2} = 1$$

asymptotes at:

$$(y-k) = \pm \frac{a}{b}(x-h)$$

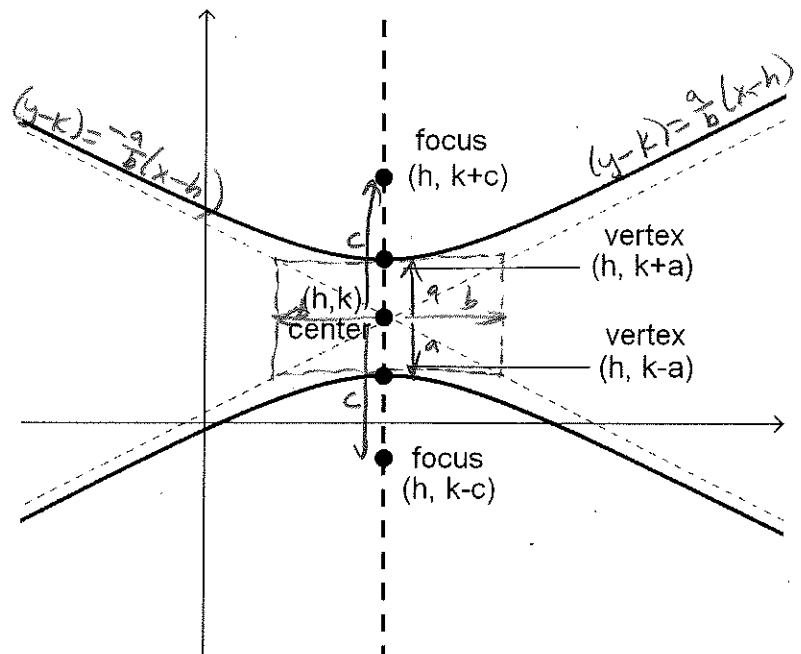

For all hyperbola:

(h, k) = center

a = distance from center to a vertex

c = distance from center to a focus

$$c^2 = a^2 + b^2 \quad \text{therefore} \quad c > a$$

Eccentricity: $e = \frac{c}{a}$ like ellipse, but now $e > 1$ (higher hyperbola eccentricity = 'flatter' curves)

#1 Find the center, vertices, foci, asymptotes, eccentricity and sketch: $\frac{x^2}{9} - \frac{y^2}{25} = 1$

$$\frac{x^2}{9} - \frac{y^2}{25} = 1 \quad \begin{array}{l} \text{X term 1st,} \\ \text{horiz transverse axis} \end{array}$$

$$\begin{array}{l} a^2 = 9, a = 3 \quad c^2 = a^2 + b^2 \\ b^2 = 25, b = 5 \quad c^2 = 9 + 25 = 34 \\ \quad \quad \quad \quad \quad c = \sqrt{34} \\ \quad \quad \quad \quad \quad \approx 5.8 \end{array}$$

Center: $(h, k) : (0, 0)$

Vertices: $(h \pm a, k) : (3, 0) \text{ \& } (-3, 0)$

Foci: $(h \pm c, k) : (\sqrt{34}, 0) \text{ \& } (-\sqrt{34}, 0)$

Asymptotes: $(y - k) = \pm \frac{b}{a}(x - h) : (y - 0) = \pm \frac{5}{3}(x - 0)$
 $y = \pm \frac{5}{3}x$

Eccentricity: $e = \frac{c}{a} = \frac{\sqrt{34}}{3}$

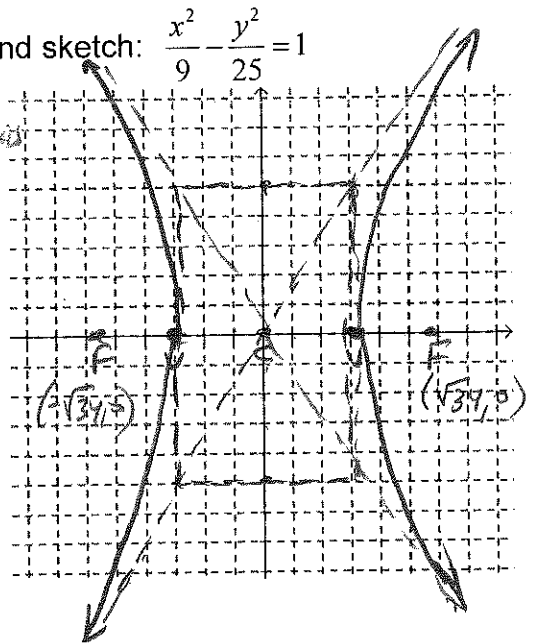

#2 Find the center, vertices, foci, asymptotes, eccentricity and sketch:

$$4y^2 - x^2 - 16y - 6x - 29 = 0$$

$$(4y^2 - 16y) + (-x^2 - 6x) = 29$$

$$4(y^2 - 4y + 4) - (x^2 + 6x + 9) = 29 + 16 - 9$$

Center: $(-3, 2)$

Vertices: $(-3, 5) \text{ \& } (-3, -1)$

Foci: $(-3, 2 + \sqrt{45}), (-3, 2 - \sqrt{45})$

Asymptotes: $(y - 2) = \pm \frac{1}{2}(x + 3)$

Eccentricity: $e = \frac{c}{a} = \frac{\sqrt{45}}{3}$

Vertical transverse axis

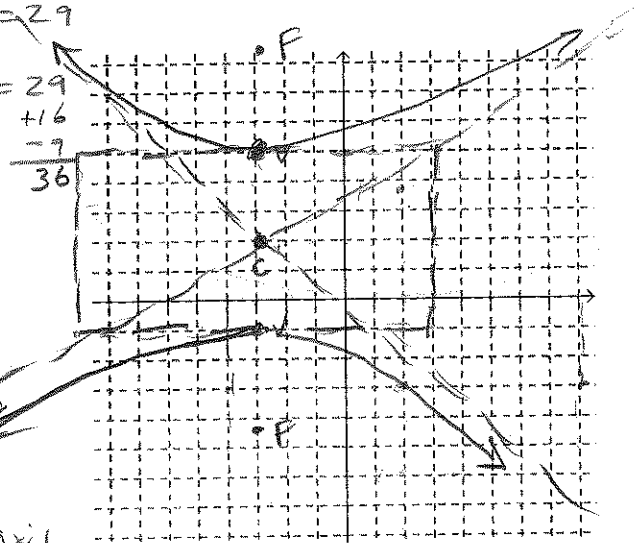

Try it... Find the center, vertices, foci, asymptotes, eccentricity and sketch:

$$x^2 - 9y^2 + 36y - 72 = 0$$

$$x^2 + (-9y^2 + 36y) = 72$$

$$(x-0)^2 - 9(y^2 - 4y + 4) = 72 - 36$$

$$\frac{(x-0)^2}{36} - \frac{9(y-2)^2}{36} = \frac{36}{36}$$

$$\frac{x^2}{36} - \frac{(y-2)^2}{4} = 1$$

horiz. trans. axis

$$a = 6$$

$$b = 2$$

$$c^2 = 40$$

$$c = \sqrt{40} \approx 6.3$$

Center: $(0, 2)$

Vertices: $(6, 2)$ & $(-6, 2)$

Foci: $(\sqrt{40}, 2)$ & $(-\sqrt{40}, 2)$

Asymptotes: $(y-2) = \pm \frac{1}{3}x$

$$\begin{aligned} \text{Eccentricity: } e &= \frac{c}{a} = \frac{\sqrt{40}}{6} = \frac{\sqrt{4}\sqrt{10}}{6} \\ &= \frac{2\sqrt{10}}{6} = \frac{\sqrt{10}}{3} \end{aligned}$$

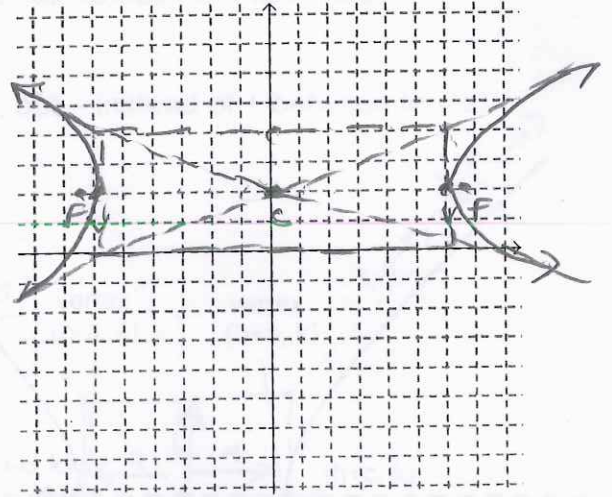

#4 Find the standard form of the equation of the hyperbola if:

center $(0, 0)$

Vertices: $(2, 0)$ and $(-2, 0)$

Foci: $(5, 0)$ and $(-5, 0)$

$$\begin{aligned} c^2 &= a^2 + b^2 \\ 25 &= 4 + b^2 \\ b^2 &= 21 \end{aligned}$$

$$\boxed{\frac{x^2}{4} - \frac{y^2}{21} = 1}$$

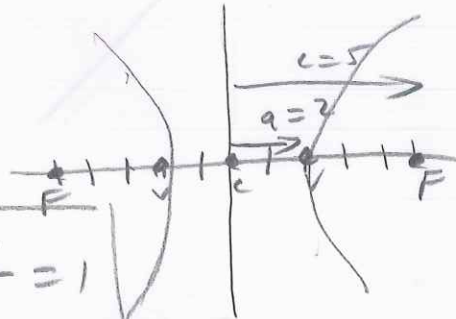

Try it... Find the standard form of the equation of the hyperbola if:

Foci: $(2, 5)$ and $(2, -5)$

Vertices: $(2, 3)$ and $(2, -3)$

$$c^2 = a^2 + b^2$$

$$25 = 9 + b^2$$

$$b^2 = 16$$

$$\frac{(y-0)^2}{9} - \frac{(x-2)^2}{16} = 1$$

$$\boxed{\frac{y^2}{9} - \frac{(x-2)^2}{16} = 1}$$

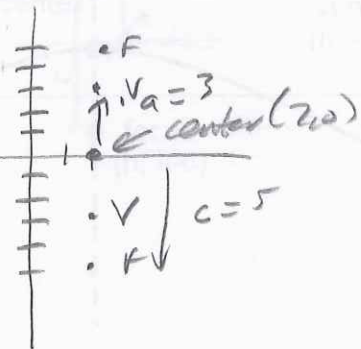

HAlg3-4, 10.3 day 2 Notes – Classifying Conic Sections by Equation

Where are hyperbolas found in the real-world? (where planes and cones intersect)

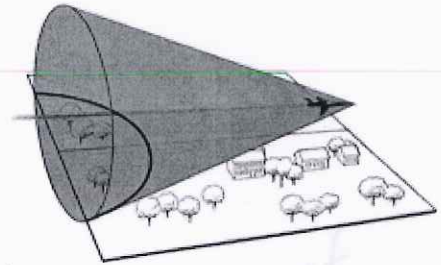
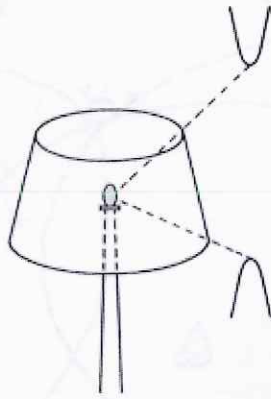

if you have two equal signs

family of conics

Classifying a conic section from the general equation:

$$Ax^2 + Bxy + Cy^2 + Dx + Ey + F = 0$$

not in this course

Look at the A and the C (the x^2 and the y^2 terms)....

$4x^2 - y^2 - 4x - 3 = 0$ H

$x^2 + y^2 - 6x + 4y + 9 = 0$ C

$4x^2 + 3y^2 + 8x - 24y + 51 = 0$ E

$x^2 + 4y^2 - 6x + 16y + 21 = 0$ E

$4x^2 - 9x + y - 5 = 0$ P

$4x^2 - y^2 - 4x - 3 = 0$ H

$4x^2 - y^2 + 8x - 6y + 4 = 0$ H

$4y^2 - 2x^2 - 8x - 4y - 15 = 0$ H

$2x^2 + 4y^2 - 4x + 12y = 0$ E

$25x^2 - 10x - 200y - 119 = 0$ P

$2x^2 + 2y^2 - 8x + 12y + 2 = 0$ C

$4x^2 + 4y^2 - 16y + 15 = 0$ C

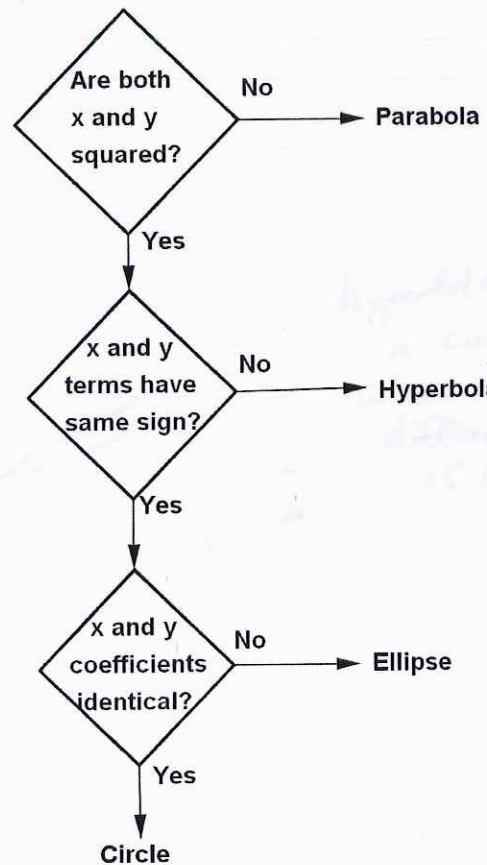

hyperbola is a curve difference is constant

HAlg3-4, Ch 10 review day – Comparing conics

Parabola

$$(x-h)^2 = 4p(y-k)$$

$$(y-k)^2 = 4p(x-h)$$

x^2 like $y = x^2$
 y^2 'other one'

p = dist. vertex to focus
 and dist. vertex to directrix

Ellipse

$$\frac{(x-h)^2}{a^2} + \frac{(y-k)^2}{b^2} = 1$$

$$\frac{(x-h)^2}{b^2} + \frac{(y-k)^2}{a^2} = 1$$

a is always bigger,
 a under term of major axis

$$c^2 = a^2 - b^2$$

b = dist. center to point
 on minor axis

Hyperbola

$$\frac{(x-h)^2}{a^2} - \frac{(y-k)^2}{b^2} = 1$$

$$\frac{(y-k)^2}{a^2} - \frac{(x-h)^2}{b^2} = 1$$

a not always bigger,
 a always under first term
 first term is transverse axis

$$c^2 = a^2 + b^2$$

a = dist. center to vertex
 c = dist. center to focus

b = dist. to 'other side of box'

asymptotes from center
 through corners of box:

$$(y-k) = \pm \frac{b}{a}(x-h)$$

$$(y-k) = \pm \frac{a}{b}(x-h)$$

(look at box to see which)

eccentricity $e = \frac{c}{a}$